

GPRS - ARCHITECTURE

GPRS architecture works on the same procedure like GSM network, but, has additional entities that allow packet data transmission. This data network overlaps a second-generation GSM network providing packet data transport at the rates from 9.6 to 171 kbps. Along with the packet data transport the GSM network accommodates multiple users to share the same air interface resources concurrently.

Following is the GPRS Architecture diagram:

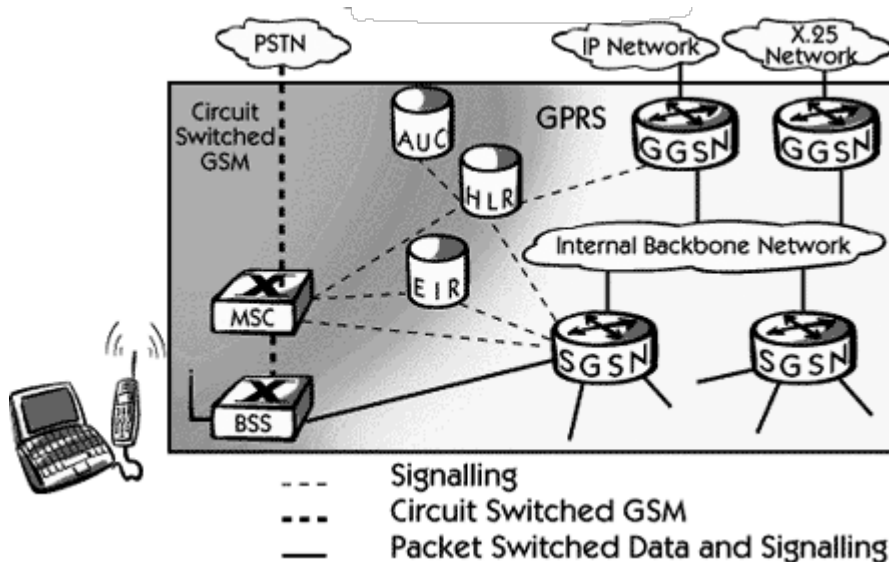

GPRS attempts to reuse the existing GSM network elements as much as possible, but to effectively build a packet-based mobile cellular network, some new network elements, interfaces, and protocols for handling packet traffic are required.

Therefore, GPRS requires modifications to numerous GSM network elements as summarized below:

GSM Network Element	Modification or Upgrade Required for GPRS.
Mobile Station <i>MS</i>	New Mobile Station is required to access GPRS services. These new terminals will be backward compatible with GSM for voice calls.
BTS	A software upgrade is required in the existing Base Transceiver Station <i>BTS</i> .
BSC	The Base Station Controller <i>BSC</i> requires a software upgrade and the installation of new hardware called the packet control unit <i>PCU</i> . The <i>PCU</i> directs the data traffic to the GPRS network and can be a separate hardware element associated with the <i>BSC</i> .
GPRS Support Nodes <i>GSNs</i>	The deployment of GPRS requires the installation of new core network elements called the serving GPRS support node <i>SGSN</i> and gateway GPRS support node <i>GGSN</i> .
Databases <i>HLR, VLR, etc.</i>	All the databases involved in the network will require software upgrades to handle the new call models and functions introduced by GPRS.

GPRS Mobile Stations

New Mobile Stations *MS* are required to use GPRS services because existing GSM phones do not handle the enhanced air interface or packet data. A variety of MS can exist, including a high-speed version of current phones to support high-speed data access, a new PDA device with an embedded GSM phone, and PC cards for laptop computers. These mobile stations are backward compatible for making voice calls using GSM.

GPRS Base Station Subsystem

Each BSC requires the installation of one or more Packet Control Units *PCUs* and a software upgrade. The PCU provides a physical and logical data interface to the Base Station Subsystem *BSS* for packet data traffic. The BTS can also require a software upgrade but typically does not require hardware enhancements.

When either voice or data traffic is originated at the subscriber mobile, it is transported over the air interface to the BTS, and from the BTS to the BSC in the same way as a standard GSM call. However, at the output of the BSC, the traffic is separated; voice is sent to the Mobile Switching Center *MSC* per standard GSM, and data is sent to a new device called the SGSN via the PCU over a Frame Relay interface.

GPRS Support Nodes

Following two new components, called Gateway GPRS Support Nodes *GSNs* and, Serving GPRS Support Node *SGSN* are added:

Gateway GPRS Support Node *GGSN*

The Gateway GPRS Support Node acts as an interface and a router to external networks. It contains routing information for GPRS mobiles, which is used to tunnel packets through the IP based internal backbone to the correct Serving GPRS Support Node. The GGSN also collects charging information connected to the use of the external data networks and can act as a packet filter for incoming traffic.

Serving GPRS Support Node *SGSN*

The Serving GPRS Support Node is responsible for authentication of GPRS mobiles, registration of mobiles in the network, mobility management, and collecting information on charging for the use of the air interface.

Internal Backbone

The internal backbone is an IP based network used to carry packets between different GSNs. Tunnelling is used between SGSNs and GGSNs, so the internal backbone does not need any information about domains outside the GPRS network. Signalling from a GSN to a MSC, HLR or EIR is done using SS7.

Routing Area

GPRS introduces the concept of a Routing Area. This concept is similar to Location Area in GSM, except that it generally contains fewer cells. Because routing areas are smaller than location areas, less radio resources are used. While broadcasting a page message.

Loading [Mathjax]/jax/output/HTML-CSS/jax.js